

SHOOTER'S BENCH

Turn Your AR Into A Switch-Barrel Semiautomatic Dream

When the 6.8 SPC cartridge was announced, it caught my attention. In addition to the cartridge's original antipersonnel purpose, it should prove ideal for teaching new shooters and for hunting medium-size game. If it catches on with the military, inexpensive surplus ammunition might even make the 6.8 a future plinker cartridge.

I eventually got to use the 6.8 afield in a Remington Model 700 AWR bolt action while hunting Alabama whitetail, but I also wanted to give it a go in the AR platform for which it was intended. But rather than invest in a whole new gun, I decided an accurate new upper for my existing AR would suffice, and by using a Lewis Machine & Tool Monolithic Rail

Platform (MRP) upper I'd also have the advantage of a quick-change barrel system. LMT's quick-change MRP upper let you make a quick switch from 5.56 to 6.8, and it also puts the performance cartridges such as the .204 Ruger, 7.62x39 and 5.45x39 in your hand with a couple twists of a wrench.

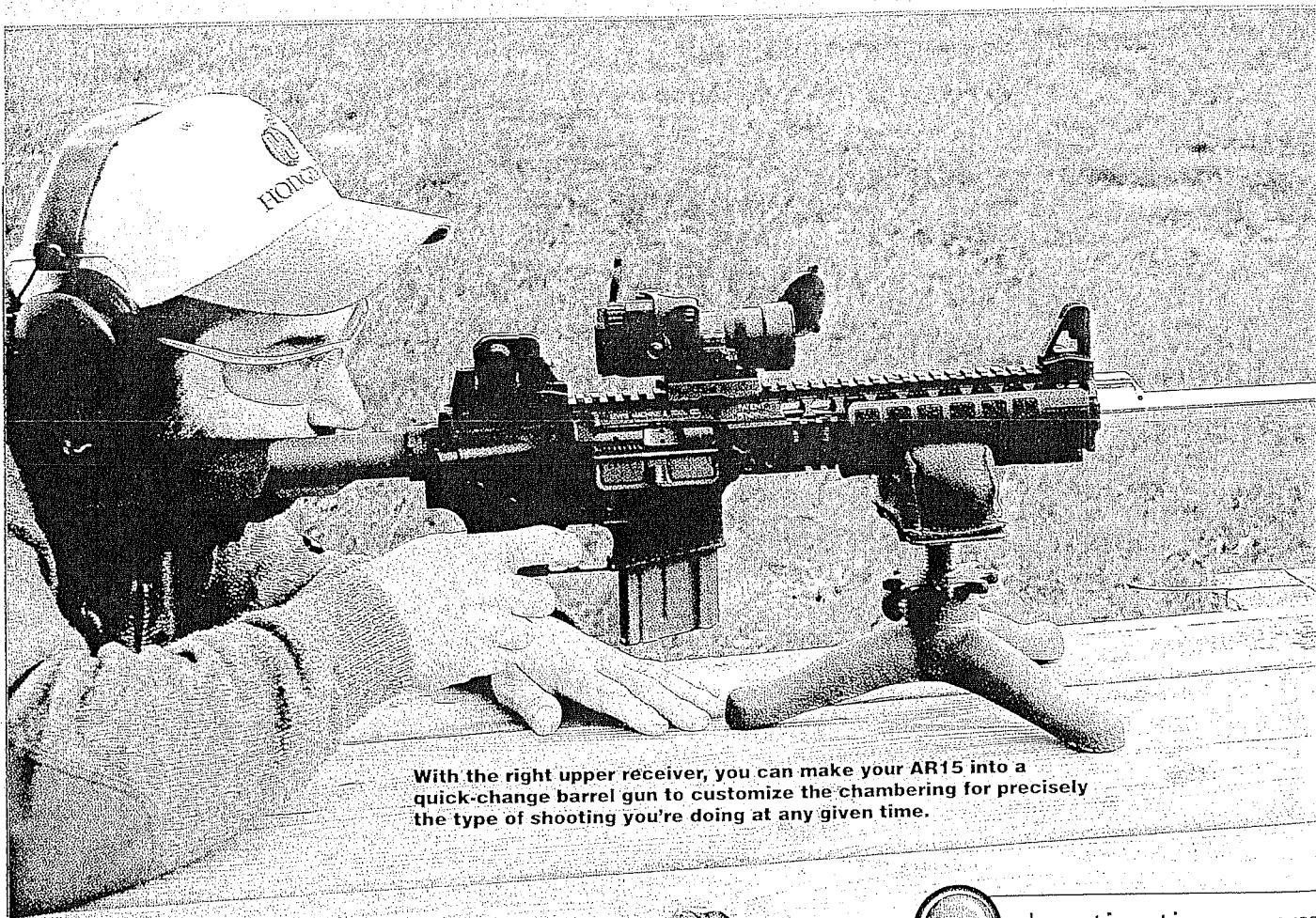

With the right upper receiver, you can make your AR15 into a quick-change barrel gun to customize the chambering for precisely the type of shooting you're doing at any given time.



shootingtimes.com

Your source for
more how-to information.

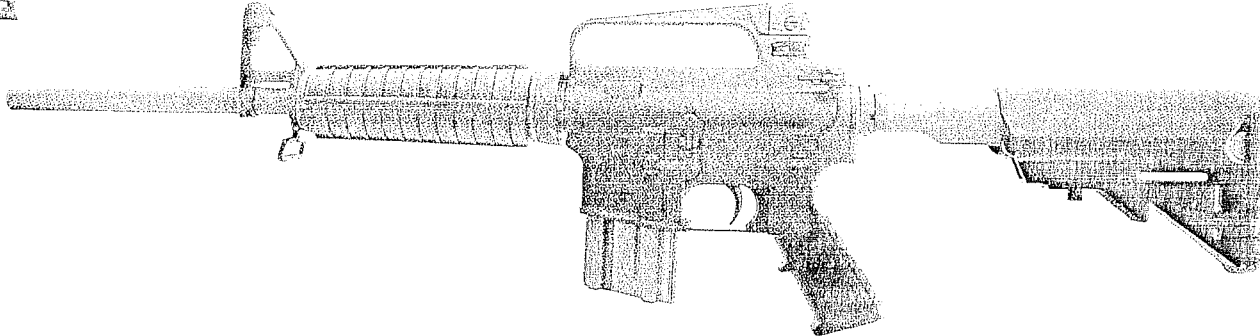

The Lewis Machine & Tool MRP upper is Mil Spec and will fit on any Mil Spec AR15 platform.

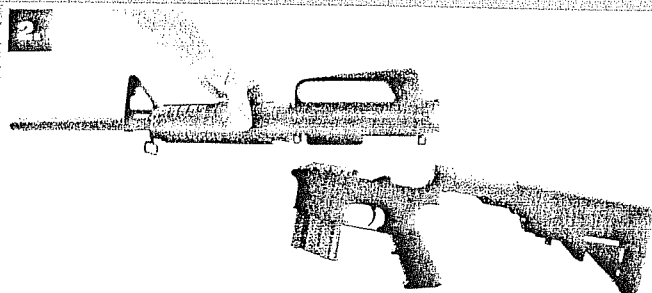

Remove the standard upper by depressing the takedown pin, pivoting the upper from the lower, and then pushing out the receiver pivot pin.

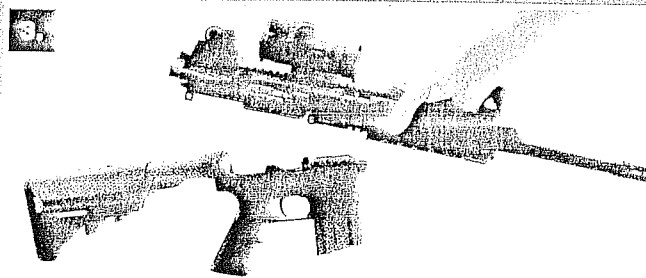

Install the Lewis Machine & Tool MRP upper in the reverse order. This is the extent of the switch if all you're doing is changing uppers.

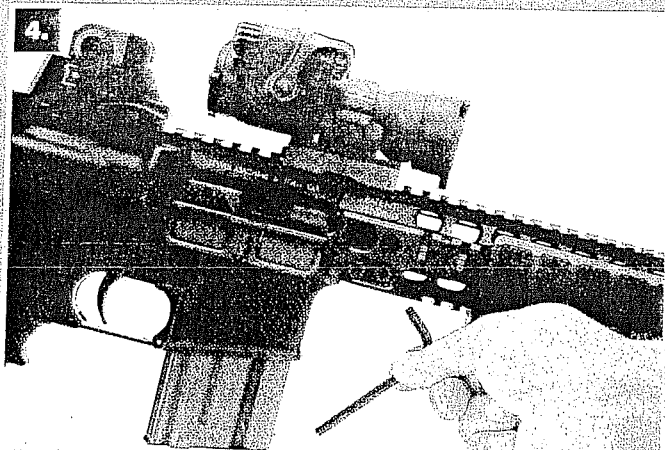

If making a barrel change, use LMT's supplied Torx wrench to fully remove the front fastening bolt and to loosen the rear bolt three complete turns.

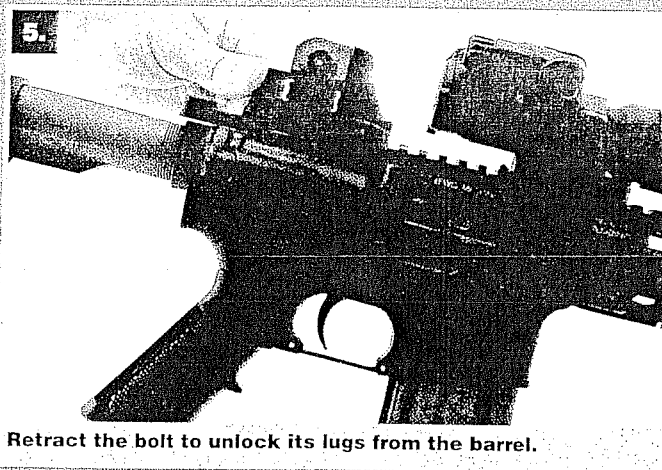

Retract the bolt to unlock its lugs from the barrel.



Remove the free-floating quick-change barrel by grasping it at the muzzle end and pulling it straight out from the receiver.

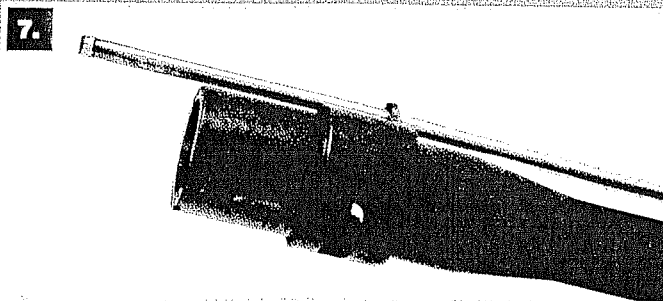

To ensure consistent assembly, a semicircular cutout in the bottom of the barrel mates with the front fastening bolt.

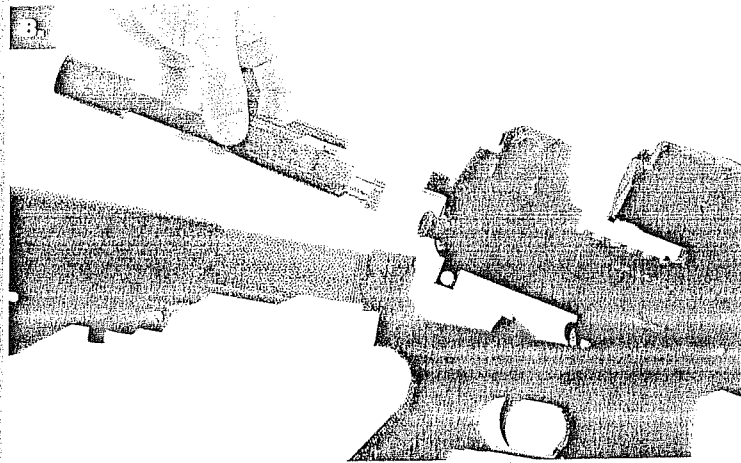

If changing to a caliber with a different case head size, it will be necessary to change bolts or just bolt heads to one of the correct size.

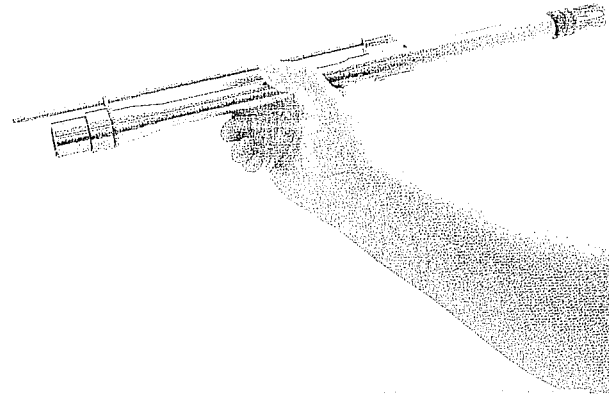
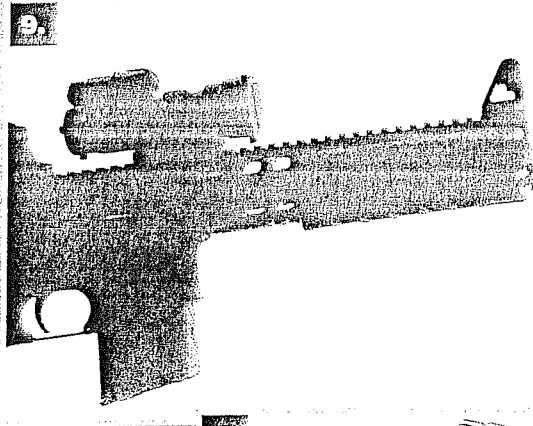

Install the new barrel, taking care to line up the straight gas tube with the corresponding hole at the 12 o'clock position in the upper receiver.

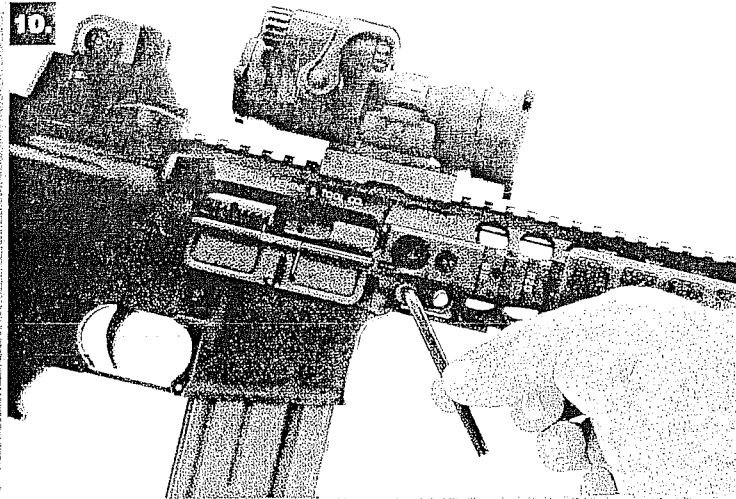

While pressing back on the barrel to ensure that it is fully seated, return the front fastening bolt and fully retighten both it and the rear bolt. Depending on the new cartridge, a different magazine may be necessary.

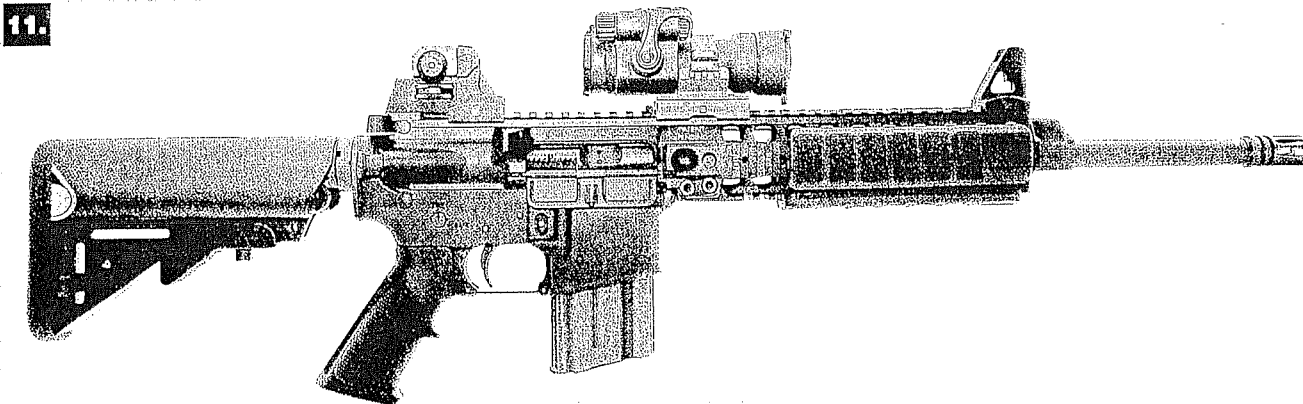

When completed, you have an extraordinary AR15 switch-barrel semiautomatic dream. 